

# AD-1250 Airflow Measuring Station

## Description

The AD-1250 Airflow Measuring Stations are accurate, economical solutions for measuring, reporting, and controlling airflow from 300 to 5,000 Feet Per Minute (FPM) (91 to 1,524 Meters per Minute [MPM]) within  $\pm 5\%$  accuracy.

The factory-assembled AD-1250 Airflow Measuring Station incorporates the following items in one 15 inch (38 mm) deep assembly:

- an ultra-low-leak, high-performance, aluminum airfoil blade/aluminum frame control damper
- an aluminum air straightener
- multiple AD-1251 Airflow Sensing Probes
- a DMPR-RA001 Differential Pressure Transducer (DPT)
- galvanized steel sleeve
- M9220-GGC-3 Electric Spring Return Actuators (optional)

Refer to the *M9220-xxx-3 Electric Spring Return Actuators Product Bulletin (LIT-12011057)* for necessary information on operating and performance specifications for the actuator.

## Features

- Air Movement and Control Association International, Inc. (AMCA) Class IA Damper
- Flanged or Slip Fit Mounting Available
- Vertical Anodized Aluminum Sensing Blades
- Factory-Piped DPT with Display
- Factory-Installed Actuator

## Repair Information

If the AD-1250 Airflow Measuring Station fails to operate within its specifications, replace the unit. For a replacement AD-1250 Airflow Measuring Station, contact the nearest Johnson Controls® representative.

All AD-1250 Airflow Measuring Stations are built to order and cannot be returned due to ordering errors. Airflow measuring stations are backed by a 1-year warranty, which covers defects in materials or workmanship. Refer to terms and conditions of sale for specifics.



AD-1250 Airflow Measuring Station

## Selection Charts

### Dimensions of Single and Multiple Panel Versions

Size Limits	Width x Height, in. (mm)
Minimum Single Panel	10 x 10 (254 x 254)
Maximum Single Panel	18 sq. ft (1.672 sq. m)
Maximum Multiple Panel with Air Straightener	640 x 300 (16,256 x 7,620)

Note: Actual size is 1/4 in. (6 mm) less than nominal.

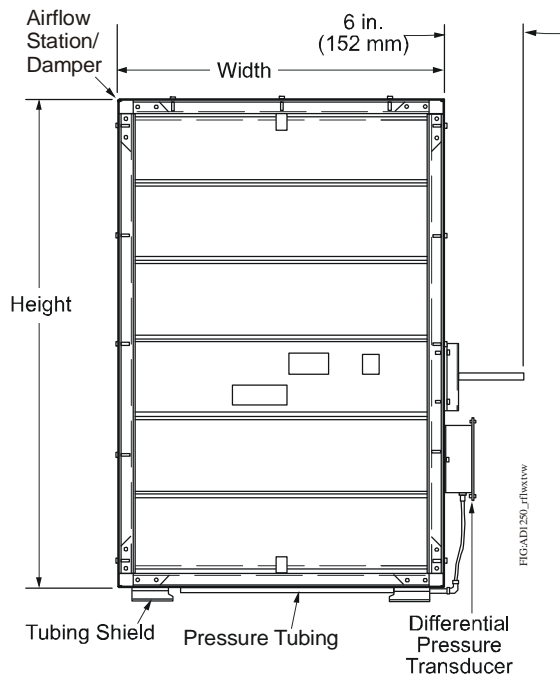

AD-1250 Airflow Measuring Station (Airflow Exit View)

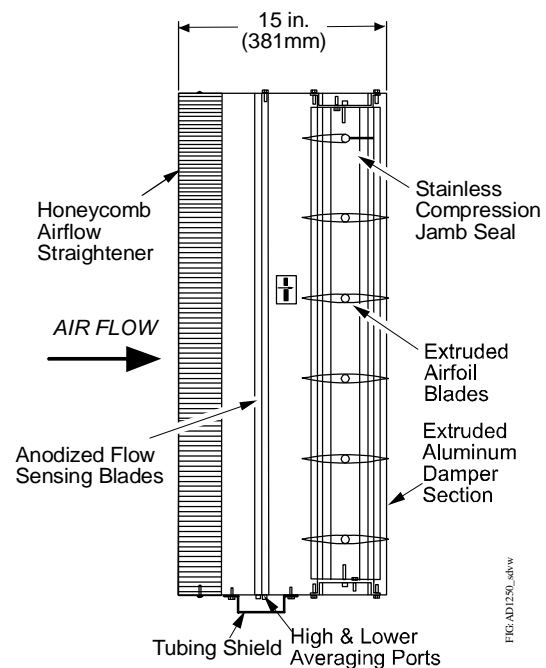

AD-1250 Airflow Measuring Station (Airflow Side View)

## AD-1250 Airflow Measuring Station (Continued)

Use the following steps to select the appropriate product:

1. Determine required size from drawings.
2. Select the part number required.
3. Enter width and height of duct.

www = width of duct (in inches)

hhh = height of duct (in inches)

**Note:** Actual probe size is 1/4 inch less than nominal.

4. Enter options required.

E = Exact whole inch size, no undercut

H = Double flange

**Example:** APESN-020x020 is an airflow measuring system with dimensions of 20 inches wide x 20 inches high, and enclosed in a 15-inch long sleeve without flanges for a slip fit.

### Valid Part Numbers

Code Number	Description
APESN-wwwxhhh	AD-1250 Airflow Measuring Station (No Actuator)
APESW-wwwxhhh	AD-1250 Airflow Measuring Station with Optional M9208 or M9220 Modulating Actuator(s) <sup>1</sup>

1. The number of factory-mounted actuators is based on published torque rating of 7 lb-in/sq ft at 1-inch static pressure. Refer to the *M9220-xxx-3 Electric Spring Return Actuators Product Bulletin (LIT-12011057)* and *M9208-xxx-x Electric Spring Return Actuators Product Bulletin (LIT-12011480)* for specifications.

### Technical Specifications

AD-1250 Airflow Measuring Station <sup>1</sup>					
<b>Leakage Resistance - Fully Closed</b>	4 CFM/sq ft maximum at 2.5 in. static pressure				
<b>Operating Torque</b>	1 in. static pressure and 1,000 FPM (305 MPM) fully open approach velocity 7 lb-in/sq. ft				
<b>Pressure Drop (inches WG) - Fully Open</b>		1,000 FPM (305 MPM)	2,000 FPM (610 MPM)	3,000 FPM (914 MPM)	4,000 FPM (1,219 MPM)
	24 x 24 in. (609 x 609 mm) 36 x 36 in. (914 x 914 mm)	0.039 0.04	0.11 0.11	0.26 0.22	0.49 0.37
<b>Velocity Requirements</b>	Minimum 300 FPM (91 MPM) Maximum 5,000 FPM (1,524 MPM)				
<b>Temperature Rating</b>	Standard Operating Conditions: -22 to 140°F (-30 to 60°C) Actuator: -4 to 122°F (-20 to 50°C)				
<b>Approximate Weight</b>	Damper: 8 lb/sq. ft (3.69 kg/sq. ft) Actuator: 2.9 lb (1.32 kg) per actuator Sensor: 1 lb (0.45 kg)				

1. Measuring stations are tested at an AMCA Certified Laboratory using instrumentation and procedures in accordance with AMCA Standard No. 610-93, Airflow Station Performance.